

fermacell



Dry Lining

Handy Guide

xella

One Unique Board.

6 major benefits from 1 multi-purpose board.

Impact resistant

Fibre reinforcement provides hidden strength, making FERMACELL the ideal choice for walls in high traffic areas such as schools and sports halls

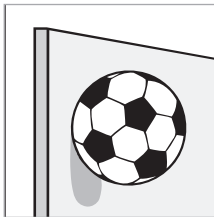

High load bearing

A single screw in FERMACELL can hold up to 30 kg, and a wallplug up to 50 kg. Noggins are not required

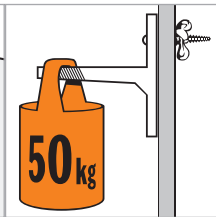

Moisture resistant

FERMACELL is the ideal wall board for kitchens and bathrooms. It can withstand humidity levels of up to 80% Rh

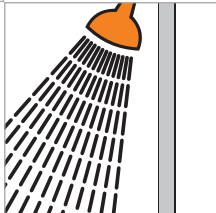

Sound insulating

Can be used for walls, ceilings, or floors where sound-proofing is required. A 100 mm wide stud wall with FERMACELL board gives better acoustic reduction than a 275 mm block wall

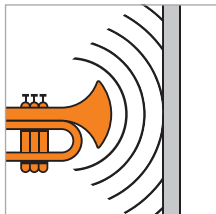

Fire resistant

All thicknesses of board are categorised as Class 0 (best). Single layers of FERMACELL can create F60 partitions

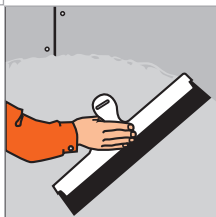

No plaster needed

The board is ready for decorating without the need for plaster. For a "glass" finish, simply apply a coat of FST. It requires no specialist skills to apply and dries in 45 minutes (depending on site conditions)

Index.

Installation Technique.....	4
Materials.....	6
Tools.....	10
Storage.....	11
Cutting.....	12
Fixing and Jointing.....	14
Finishing.....	18
Partition Details.....	22
Dry Lining Details.....	32
Fixing Centres – Walls.....	34
Ceiling Details.....	36
Other Details.....	38
Repairs.....	48
Questions and Answers.....	51
Product Range.....	58

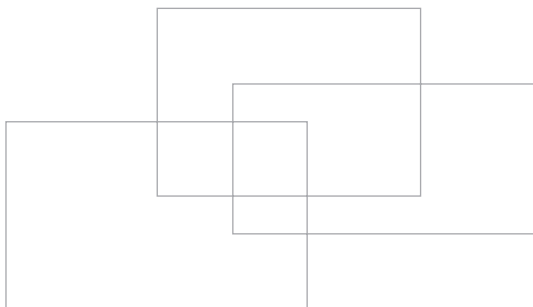

Unique installation technique.



1. stick

Simply glue the board edges with FERMACELL Jointstik before you butt and fix the boards. Glued joints require no taping and are set within about 24 hours

2. screw

Boards are cut with wood-working tools and fixed with FERMACELL screws or suitable staples.

Non-factory cut edges are left 5–7mm apart and jointed with FERMACELL Joint Filler later

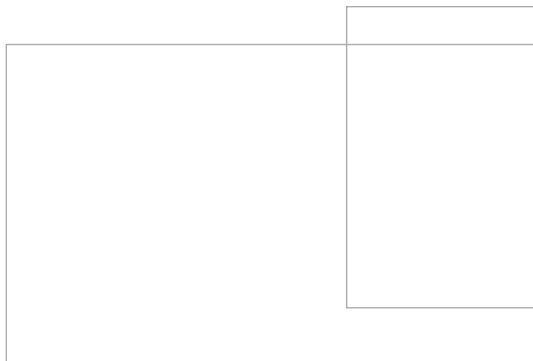

it's simple
it's tough

No plastering, no kidding.

3. scrape

Scrape off excess Jointstik. Fill any gaps or screw heads with FERMACELL Joint Filler. The boards are then ready to paint, tile or paper

4. squeegee

For a "glass" finish, simply spread with ready mixed Fine Surface Treatment, squeegee the surface to remove excess, and wait 45 minutes. A perfect finish with no plastering

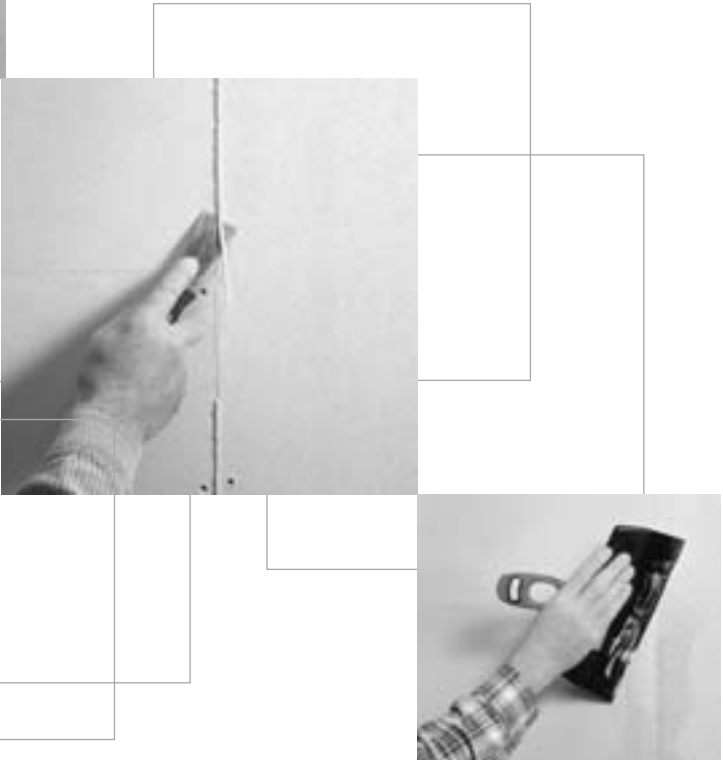

high performance wall
at no extra cost

Materials.

The following 10 points will help you estimate the quantities required to build a partition wall. The guidance is similar for ceilings and dry lining although you will need to re-estimate the quantities in accordance with the usage tables in each section. The quantities are intended for guidance only. An accessories calculator is available at www.fermacell.co.uk



1. Studwork.

If you are using timber for the subframe, you will need 3" x 2" (75 mm x 50 mm) P.S.E. well seasoned timber for both the vertical studwork and the head and floor track.

If you are using a steel subframe, use 75 mm x 50 mm x 0.6 mm galvanised steel U section for the head and floor track. FERMACELL recommends Protektor studwork. This is available from Cornercare +44 (0) 1562 515200.

Allow for full height stud every 500 mm of wall length when using 1500 mm x 1000 mm one-man boards, or every 600 mm of wall length when using other sizes in 12.5 mm thickness or every 400 mm of wall length when using 10 mm thickness, plus one extra stud for the final wall fix. Allow two times the wall length for the head and floor tracks.

2. Fixings.

For the timber frame, use 3½" approximately (82.5 mm) screws with wall plugs (if appropriate) for fixing head and floor tracks and end studs to the existing structure. Allow for fixing at 24" (600 mm) centres. Use 4" (100 mm) round headed nails for skew fixing the studs to the head and sole plate. 3 per fixing, (6 per stud). For the steel frames, use 1½" screws with wall plugs (if appropriate) for fixing head and floor tracks and end studs to the existing structure. Allow for fixing at 24" (600 mm) centres. Intermediate studs are not fixed to the head and floor track.

3. Flanking strips.

Mineral fibre insulation strips 2" to 3" wide (50 mm to 75 mm) and 3/8" (10 mm) thick. These can be either purchased as a roll or may be offcuts from the insulation material from the wall (see 4 below). These strips are placed between the head and floor track and the end studs, and adjoining surfaces to prevent flanking sound transmission.

4. Mineral fibre insulation.

For most general applications we recommend 40 mm thick, 45 kg/m³ ("40/45") mineral fibre insulation batts or roll. The width of the insulation should match the stud spacing (see 1 on previous page).

This grade of insulation gives excellent all round thermal and acoustic properties and when used in conjunction with 12.5 mm board provides F 60 partitions (constructions 1 S 21 and 1 H 22)



Materials.

5. FERMACELL boards.

Use either 1200 mm x 1200 mm or 1500 mm x 1000 mm one-man boards or full size boards (typically 2400 mm x 1200 mm). FERMACELL is normally available in 10 mm or 12.5 mm thickness, and the thickness of board to use depends upon the ultimate requirements of the construction. For the majority of domestic constructions 10 mm FERMACELL is sufficient. If greater strength, sound insulation or fire rating is required, 12.5 mm should be used.

When choosing board size, consider the accessibility of the site and what if any assistance is available. If boards are to be carried upstairs by one person, we strongly recommend the use of the one-man board.

6. FERMACELL screws.

The boards should be screwed to the studs using FERMACELL screws (3.9 x 30 mm) at 250 mm centres along the studs. This means for 500 mm stud spacing, 26 screws per m², and 24 per m² for 600 mm stud spacing.

FERMACELL may also be fixed to timber subframes using pneumatically fired resinated galvanised staples or galvanised ring shank nails. Staples should be 38 mm long, have a head width of 10 mm and be of 1.4 mm gauge. Nails should be 45 mm long.





7. FERMACELL Jointstik or jointing tape.

For use in gluing square edge boards together. Each cartridge will cover 20 linear metres of joint using a 3 mm bead. This equates to approximately 8 boards.

If using Tapered edge boards, jointing tape will be required. We recommend a paper tape rather than a self adhesive fibre tape as this gives a stronger joint.

8. FERMACELL Joint Filler.

A hard filler used for jointing tapered edge boards, jointing the gaps between scored and snapped boards and for filling screw heads, etc. When using FERMACELL Joint Filler for jointing tapered edge boards, allow 1 kg per 4 metres of joint length, and 1 kg per 7–8 metres of joint length for jointing offcuts.

9. Flexible sealant.

For use in sealing the gap between boards and other surfaces such as walls, floors and ceilings. The edges of the boards must be primed prior to application.

10. FERMACELL Fine Surface Treatment.

A ready-mixed filler used for smoothing the surface of the boards and for filling screw heads, etc. A 10 litre tub will cover approximately 60m² of wallboard. FST is used where a skim-coat smoothness is required.

Remember to allow for offcuts and other wastage, and that both sides of the studwork will be covered.

Tools.



The tools you will need

- Electric screwdriver with a minimum speed of 3500 rpm. A cordless screwdriver may be used, but check the speed first. Slower speed tools may cause lipping when installing boards on steel studwork.
- If using staples or nails, a pneumatic gun and compressor operating at 7 bar will be needed. (This equipment is available from many hire centres.)
- Saw (hand, jig or circular)
- Plumb line or long spirit level
- Mastic gun for Jointstik tubes
- Decorator's scraper or similar for removing excess FERMACELL Jointstik and applying FERMACELL Joint Filler to the joint.
- Rigid bladed scoring knife for cutting the boards. A special FERMACELL knife is available from selected distributors
- Sandpaper for smoothing the joints
- Decorator's sponge for finishing the joints
- A clean bucket for mixing filler
- A steel float or squeegee for applying FERMACELL Fine Surface Treatment. Special FERMACELL applicators are available from selected distributors

FERMACELL is easy to work with and can be installed using everyday tools.

Storage.

FERMACELL boards are delivered on pallets and are protected from the elements by a plastic film. On site, you should store boards on a flat, even surface and keep them dry. Damp boards should not be used until they have dried out. For easy movement and to prevent damage, carry the boards on edge.

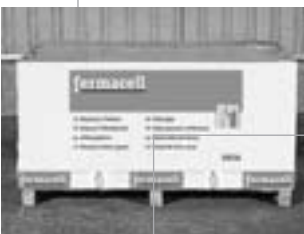

Boards are delivered on pallets

Cutting.

You'll find FERMACELL easy to work with. Boards can be screwed or stapled into place. Glued joints require no taping and are set the following day. Paint, tiles, paper or a variety of wall coverings can be applied to the boards.

Cutting boards to size.

Cutting boards to size is simple. First mark the cutting line and then score it (one side only) with a FERMACELL board knife along a straight edge. Then break off the scored section as shown here.

Snapping off a scored section of board



Scoring a board using FERMACELL board knife



Hand sawing



Using an electric saw

Hand or electric saw.

Boards can also be cut using a hand or electric saw (blades should be tempered or hardened steel). If you use a hand-held electric circular saw, we recommend using a vacuum attachment to collect dust. Saw blades with fewer teeth, and lower saw speeds create less dust.

Planing smooth.

It is not necessary to plane cut edges smooth. However, planing is recommended if edges are visible. Non-planed edges can be jointed using FERMACELL Joint Filler.



Planing edges

Fixing and Jointing.

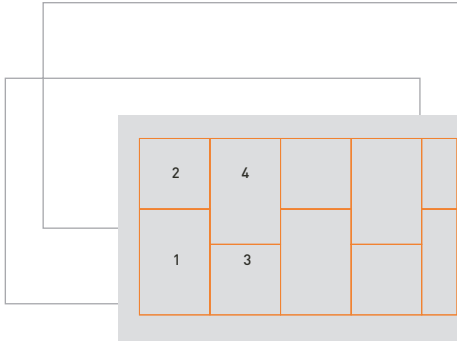

Diagram A: Fixing sequence for double height partitions



Fixing the boards on a timber subframe with staples

Fixing.

These notes cover the common techniques for fixing FERMACELL in partition, dry lining or ceiling applications. There are specific techniques that relate to the individual areas of application – please consult the relevant section. Boards are fixed using FERMACELL cross slot screws to within 10 mm of the edge of the board. They may also be fixed to timber subframes using pneumatically fired staples or nails.

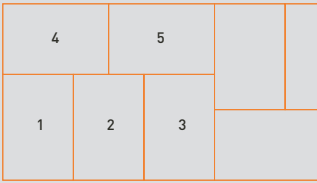

Diagram B: Fixing sequence for 1500 x 1000 one man boards

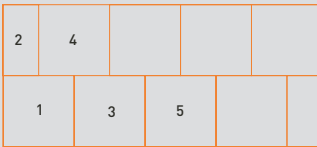

Diagram C: Fixing sequence for 1200 x 1200 one man boards

Fixing sequence.

FERMACELL boards are available in two formats – square and tapered edge. Square edge boards are mounted in a sequential manner and each board is jointed as it is installed. Once boards have been fixed they cannot be retrospectively jointed using FERMACELL Jointstik adhesive. If for any reason boards have been installed incorrectly without Jointstik adhesive then the remedial action described on page 49 must be followed.

Tapered edge boards are butt jointed and retrospectively filled using FERMACELL Joint Filler. Please note that tapered edge boards may not be used for loadbearing constructions.

When fixing boards in a double height partition, cross joints must be avoided by installing boards as shown in Diagram A. When fixing boards, work from one side of the board to the other (e.g. from left to right) or from the centre outwards. Don't fix the four corners first as this can set up stresses in the board. Ensure that there is a gap at junctions with other adjoining surfaces. This applies to both layers of a double layer partition system. When using FERMACELL square edge one man boards (1500 mm x 1000 mm), you should alternate the orientation of the boards as shown in figure B. This sequence prevents cross joints. A similar system for using 1200 mm x 1200 mm taper edge boards (tapered on 4 sides) is shown in figure C. All joints should be staggered by a minimum of 200 mm both horizontally and vertically.

Fixing and Jointing.

Fixing and jointing square edge boards.

FERMACELL Jointstik adhesive is applied to the edge of the board in a continuous 3 mm bead prior to fixing the next board. Because the adhesive expands on contact with air, the bead should be applied to the centre of the edge of the board and not the 'V' between board and subframe. If the bead is applied here, excess Jointstik may be trapped between board and subframe and cause subsequent lipping. The next board is then fitted to the subframe, spreading the adhesive across the face of the joint and ensuring that the joint gap is less than 1 mm. Fix as before. Allow the adhesive to harden fully before attempting to remove any excess (typically 24 hours). Once hardened, the excess can be struck off with a decorator's scraper or any similar tool. There is no requirement for noggins behind these joints. The final gap between boards when jointing with FERMACELL Jointstik adhesive should be less than 1 mm. Gaps greater than this may result in weaker joints and possible show through with certain paint finishes. If Jointstik has been left longer than 24 hours and is hard to remove, use a Surform or any similar tool. The joint and screw heads should then be filled with FERMACELL Joint Filler. All joints above 2500 mm partition height must be jointed using FERMACELL Jointstik adhesive or reinforced with noggins. Horizontal joints are jointed in the same manner as vertical ones.

Fixing and jointing tapered edge boards or offcuts.

Tapered edge boards are fitted to the subframe with the boards touching each other. Once installation is complete, the boards are jointed using FERMACELL Joint Filler. The filler is applied to the joint, ensuring that the central 'V' is fully filled, paper tape is bedded into the joint and a second fill applied. Self adhesive fibre tape may be used instead of paper tape and the filler pushed through the holes to the back of the joint. Please note that the joint strength when using fibre tape is less than paper tapes and cracking may occur in certain circumstances. Once the first fill is dry, a second fill may be necessary to take up any slump. Because FERMACELL Jointfiller is a combined filler, adhesive and sealant, it is not necessary to seal the (routed) edge profile of FERMACELL tapered edge boards prior to jointing.



Jointstik is applied to the edge of the board

Jointing Tapered edge boards



→ ← 5-7 mm

Allow a 5-7mm gap when jointing offcuts

Unlike normal installation of square edge FERMACELL boards, offcuts are installed prior to jointing. A 5-7 mm gap is left between boards, which is then filled with FERMACELL Joint Filler (FERMACELL Joint-stik adhesive is not a gap filler). The filler can then be rubbed down prior to final decoration. Please note: FERMACELL Joint Filler sets to a very hard finish. For this reason we recommend that only the immediate area of the joint or screw head is filled and that excess filler is not applied.

Remove excess filler

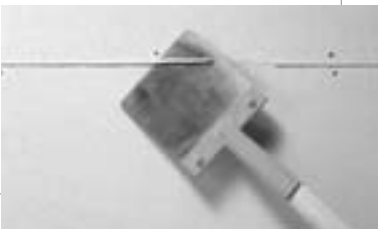

Finishing.

Preparation of surfaces.

The surface to be treated should be dry and free of stains and dirt, and any damage or indentations filled with FERMACELL Joint Filler and allowed to dry. Before any decoration, the moisture content of the boards must be less than 1.3%. This moisture content level will be attained automatically within 48 hours if the relative humidity of the air is kept below 70% and the air temperature is over 15°C during this period, and if the boards are stored off the ground in well ventilated conditions.

Joint finishing.

After sanding, brush off any loose dust. The joint can then be textured to match the texture of the board. This is done using a thin slurry coat of ready mixed filler applied with a damp jointing sponge. Rub the slurry coat on to the joint and then finish off with a light dabbing motion. This will put a light stipple on the joint which will disappear when painted.

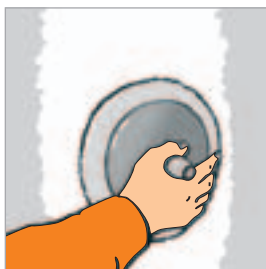

Stippling the joint
(matt emulsion
paint finishes)



Wallpapering

Wallpapering.

With the exception of vinyl wallpapers, all types of paper can be applied to FERMACELL using standard trade pastes without priming the surface beforehand. When using vinyl papers it is recommended that the board is primed and a low water content paste is used. Because FERMACELL is homogeneous, the boards can be repeatedly repapered.

Painting.

FERMACELL boards are ready to paint. Where conventional trade matt emulsions are used, the joint should be stippled as described above, and a mist and two undiluted top coats of emulsion applied with a roller. Where thinner retail paints are considered, or a semi-gloss finish such as a vinyl silk paint is to be applied, the use of FERMACELL FST is recommended to provide a very smooth final surface. We do not recommend the use of eggshell paint finishes. However, where eggshell paints are used, a minimum of two coats of FERMACELL FST should be used, followed by a sealant and the surface must be smooth and free from defects.

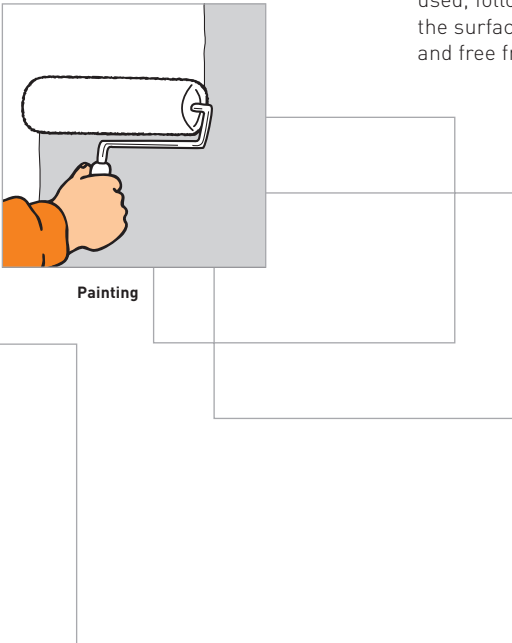

Painting

Fine Surface Treatment (FST).

FST is applied to the board surface direct from the tub using a squeegee, a steel float or a 250 mm FST applicator. Work only on 1–2 m² at a time and ensure that the surface is fully covered. Then remove all excess FST (returning it to the tub). You can use the same tool for this, or a wider, 450 mm FST applicator. The FST will dry within 45 minutes and a second layer can be applied if desired. If necessary, flat the surface with 200 grit sandpaper or an offcut of FERMACELL prior to further decoration. You will find it easier if you work from the bottom of the board to the centre, followed by the top of the board to the centre.

Tiles.

If a priming coat is required by the adhesive manufacturer, this should be allowed to dry for 24 hours before tiling work commences. Surfaces subject to frequent splashing should be treated with a waterproof sealant. Tile adhesives with a low water content should be used and tiles fixed using a thin bed method without pre-wetting. Follow the adhesive instructions and observe the tile manufacturer's recommendations.



Fine Surface Treatment (semi-gloss finishes)

Plaster and textured plasters.

Both smooth and textured plasters can be applied to FERMACELL. The use of a smooth plaster is not normally recommended as the same finish can be achieved using FST much faster and at a fraction of the cost. Where plasters are being applied, all joints must be reinforced with a fibre tape fixed with PVA adhesive, and a sealant (diluted PVA or similar) applied to the surface of the board.

It is recommended that a test area is tried first as some plaster formulations will crack under certain climatic conditions.

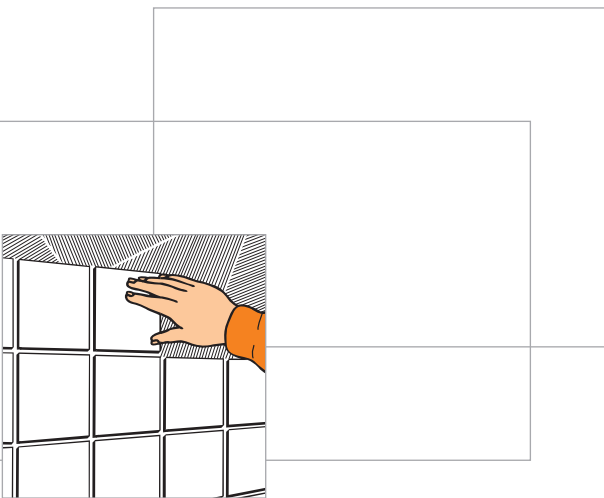
**Tiles**

Partition Details.

Building partition walls using FERMACELL is fast and easy. Just follow these steps.

Measuring and scoring.

The position at which the walls are to be built should be marked on the floor using a chalk line. If the studs are not fixed immediately after the positions of the partitions have been located, a permanent marker should be used.

Next, using a spirit level or a plumb line, transfer the position of the partition from the floor to the ceiling. For larger projects, a construction laser is recommended.

The position of door frames and load bearing members should also be located and marked on the floor.

Fixing the studwork.

FERMACELL can be fixed to either timber or steel studwork – the choice is yours. Timber is often a more familiar and readily available material, and may be more appropriate in certain circumstances – for example in timber frame housing – whilst steel studwork is lighter, generally faster to install and has better acoustic characteristics. The layout of the partition remains the same for both systems, although the actual installation is different.



Setting the position of the partition with a chalk line

Partition walls Table 1 – Stud spacing.

Multiplying factor for board thickness	Maximum stud spacing*	
	10 mm	12.5 mm
50 x t	500 mm	625 mm

* Figures are based on constant atmospheric conditions with relative humidity levels of up to 80%



Fixing C studs to the walls



Lay down U channel to the floor

Steel studwork.

The U channels at the base and head should be fixed to the floor and ceiling, in the positions already marked. The two end vertical C studs can now be fixed in position. There should be a 10 mm thick mineral wool insulation strip between these components and the adjoining building element.

The maximum distance between fixings should be 700 mm horizontally and 1000 mm vertically. The distance between fixings must be reduced when connecting to uneven surfaces.

In order to fulfil the fire protection and sound insulation requirements, connections should be installed using the appropriate materials. To achieve this, intumescent or acoustic flexible sealants can be used. Mineral wool insulation strips should also be incorporated in the connection. In general, fire resistant sealants should be used for partitions where an element of fire protection is required.

Partition Details.

If the partition being constructed is a double stud system, two separate parallel sub-frames are installed in the same way as a single stud system but with a small air gap – typically 10mm – separating the two frames.

The C studs are inserted perpendicularly into the U channels. Please note: the vertical studs should not be fixed mechanically, but should be cut short of the ceiling height by 15mm and floated within the channel. It is also important that all C studs 'face' the same way. The direction in which they face is decided by the sequence in which the boards will be installed. Where two boards are fixed to a stud, as at a joint, the first board to be fixed should be fixed to the 'open' side of the C stud.

Therefore, if you plan to fix boards from left to right as you look at the partition, the C studs should all have their open side facing to the left.

The vertical C studs are positioned roughly at the required centres with the open face towards you and turned through 90° to lock it into place. The distances between the vertical C stud centres depend on the thickness of the board being used. Please see table 1 on page 23 and section 1 of Materials (page 7). The first board can now be fixed in position.

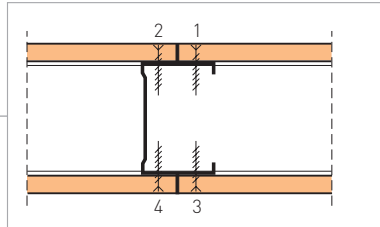

Fitting the C studs in place

The order of fixing when mounting FERMACELL on a steel subframe



Installing
timber studs

Horizontal studs – noggins (or dwangs in Scotland) are not normally required behind boards jointed using the Joint-stik method. This is because the jointing system provides a joint as strong as the board itself, and the boards can carry very heavy loads without additional support (see page 41). However, noggins are required behind horizontal joints formed using Tapered edge boards.

If a double metal stud system is being constructed, an air gap between the C studs should be maintained to achieve the best sound insulation results. If the partition height is greater than 3000mm, stability of the partition should be maintained by incorporating cross bracing or similar between the parallel C studs.

Timber studs.

The sole and head plate should be fixed to the floor and ceiling, in the positions already marked. The two end vertical studs can now be fixed in position. As with steel studs, there should be a 10mm thick mineral wool insulation strip between these components and the adjoining building element.

The maximum distance between fixings should be 700mm horizontally and 1000mm vertically. The distance between fixings must be reduced when connecting to uneven surfaces.

Partition Details.

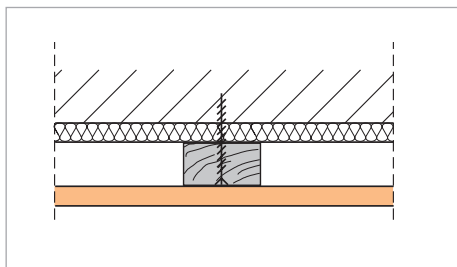

In order to fulfil the fire protection and sound insulation requirements, connections should be installed using the appropriate materials. To achieve this, intumescent or acoustic flexible sealants can be used. Mineral wool insulation strips should also be incorporated in the connection. In general, fire resistant sealants should be used for partitions where an element of fire protection is required. When sealants are used, they should be suitable for use with gypsum based boards, and the FERMACELL board should be primed before the sealant is applied.

If the partition being constructed is a double stud system, two separate parallel subframes are installed in the same way as a single stud system but with a small gap – typically 10 mm separating the frames.

The vertical studs are fitted perpendicularly to the head and sole plates with nails or metal angles at the appropriate centres given in table 1 on page 23.

As with steel subframes, horizontal studs – noggins (or dwangs in Scotland) are not normally required when using the Jointstik method of jointing square edge boards, but should be used when using installing Tapered edge boards.



Using traditional dot and dab is not recommended for fitting FERMACELL. This is because a weak adhesive joint between the dab and the masonry can reduce the exceptional weight carrying capacity of FERMACELL. It is also difficult to align square edge boards that are edge glued with FERMACELL Jointstik. For this reason, mechanical fixings using timber battens (typically 2" x 1" – 50mm x 25mm) or metal firrings screwed to the wall provide a better result. The latter can also be dabbed using a mechanical backup. All of these will provide a suitable subframe for the adhesive jointing system.

The method of fixing FERMACELL is given on pages 4 and 5.

FERMACELL is not supplied with pre laminated insulation as this limits consumer choice in selecting the appropriate thickness and type of insulation according to specific thermal requirements. When dry lining, we suggest that the insulation is fitted against the wall and the battens or metal firrings are then fixed through the insulation into the wall using frame anchors or similar. This method helps prevent cold bridging and provides a useful service cavity.

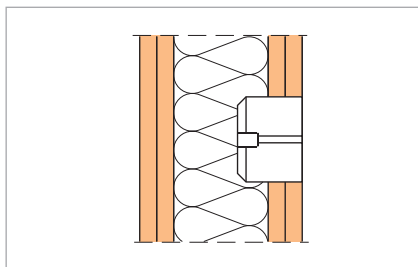

Electrical and other services.

Electrical and other services can be installed both horizontally and vertically in the void in the partitions before fitting mineral wool insulation and the FERMACELL boards. Vertical studs should be drilled in the appropriate positions to allow building services to be passed through the studs. Any services should be adequately protected and installed by a suitably qualified person.

In acoustically sensitive partitions (and ceilings) such as party walls or floor/ceiling constructions, service penetrations should be avoided. However in certain areas (e.g. kitchens) this may be difficult and the use of a sacrificial lining should be considered. Timber battens or metal firrings are fitted to the original FERMACELL wall (it is not necessary to fix through to the subframe) and services laid in the new cavity. Once complete the cavity is closed with a final layer of board.



Where penetrations into the original lining are unavoidable, these should be made good by boxing in or backing the penetration area with a pad of the same thickness of FERMACELL that extends 100 mm in each direction from the edge of the penetration, and packed with mineral wool. Under no circumstances should penetrations on both sides of the partition occur within the same stud, as this will seriously compromise the performance of the construction.

Where specific or higher levels of sound insulation or fire performance are required, take care to ensure that any openings do not adversely affect the performance of the partition as a whole. This can generally be achieved by adding a pad of the same thickness FERMACELL to the board behind the opening and ensuring that the mineral fibre is continuous behind the opening. The pad should extend beyond the limit of the opening by a minimum of 100 mm in each direction. Avoid more than one opening per vertical stud.

Partition Details.

Installing mineral fibre.

If needed, mineral fibre insulation, preferably in the form of rigid batts, can be installed in the spaces between the studs in the FERMACELL partitions.

The thickness and density of the mineral fibre installation will depend on the sound insulation and fire protection requirements of the partition. Please see the relevant test data for more details. Typical constructions showing the fire

performance and sound insulation values are shown on page 45–47, and full details are available from: www.fermacell.co.uk

The mineral fibre insulation should be a sufficiently tight fit to prevent the material slipping. Gaps or holes within the insulating material reduce the sound insulation and fire protection, as well as the thermal performance. Double layers of insulation should be fitted staggered.



Installing mineral wool insulation batts



**Mounting the boards
on a timber subframe**

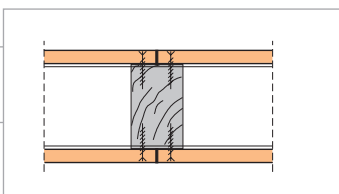

**Layout of FERMACELL
on a timber subframe**

**Layout of FERMACELL
on a steel subframe**

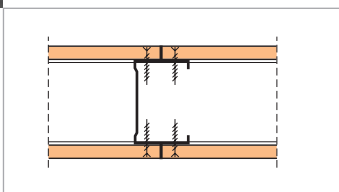

Fixing FERMACELL to the subframe.

The boards can now be fixed to the subframe using the techniques described on pages 14–17. It is important to note that FERMACELL boards are fixed symmetrically on the vertical studs, ie the boards are mounted on the same studs either side of the partition. This prevents distortion in the partition (see pictures A and B).

The order in which each board is fixed with FERMACELL screws to the vertical C studs can be seen on page 14/15.

When fixing FERMACELL to steel subframes, the boards must only be fixed to the vertical C studs. And when installing on timber studwork, boards must be fixed to both vertical studs and horizontal head and floor tracks.

Normally, FERMACELL boards should be mounted vertically on the subframe. Ideally the length of the boards should correspond to the height of the room, minus 10 mm for the joints at the top and bottom of the boards.

Where curved partitions are being installed, only large format boards (typically 2400 mm x 1200 mm or greater) should be used and the boards should be installed sideways. Stud centres should be reduced to 250 mm or less. It is recommended that 10 mm boards are used in this instance.

Dry Lining Details.

Using traditional dot and dab is not recommended for fitting square edge FERMACELL boards as it is difficult to align square edge boards that are edge glued with FERMACELL Jointstik. For this reason, mechanical fixings using timber battens (typically 2" x 1" – 50 mm x 25 mm) or metal firrings screwed to the wall provide a better result. The latter can also be dabbed using a mechanical backup. All of these will provide a suitable subframe for the adhesive jointing system. The method of fixing FERMACELL is given on pages 4 and 5.

If you wish to install FERMACELL using dot and dab, then select tapered edge boards. It is important to note that the surface to which the boards are to be bonded should be clean, dry and mechanically stable. Plaster dabs (bonding compound) should be put on

the back of the board, covering the whole of the perimeter of the board, together with a central (vertical) line of dabs at 250 mm spacing. The boards are offered up to the wall and pressed firmly until adhesion takes place, and then levelled vertically, horizontally and diagonally. The same procedure is carried out for subsequent boards, ensuring that the boards align with each other in all three dimensions, providing a smooth, flat wall.

Once the bonding compound has set, all other procedures for the normal installation of tapered edge boards should be followed. Ensure that a gap between the boards and other building elements of c. 5 mm is left. For dot and dab, you also need to allow for at least one mechanical fixing (frame anchor or similar) on each board as a safety factor.



Fixing method for metal firrings



Fixing method for timber battens

With all external wall constructions, consideration should be given to the risk of condensation. In general a proprietary vapour barrier should be used immediately behind the board. The vapour barrier should be free from defects and tears, and all joints should be overlapped by 250 mm and taped. Where breathing wall constructions are being considered a Condensation Risk Analysis should be undertaken by a suitably qualified building professional.

FERMACELL is not supplied with pre laminated insulation as this limits consumer choice in selecting the appropriate thickness and type of insulation according to specific thermal requirements. Similarly, a vapour control layer, if required, should be installed separately. For this reason, we suggest that where insulation or vapour barriers are to be used, the boards (either tapered or square edge) are fixed using mechanical means rather than using dot and dab. The insulation is fitted against the wall and the battens or metal firrings are then fixed through the insulation into the wall using frame anchors or similar. This method helps prevent cold bridging and provides a useful service cavity. A vapour barrier is then fitted over the face of the battens.

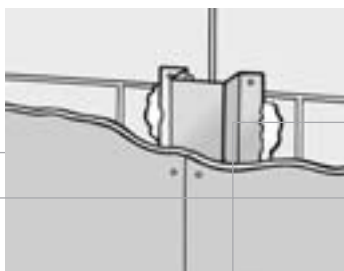

**Metal firrings fixed
on dabs with
mechanical back up**



Fixing Centres – Walls.

Fixing centres and accessory usage Table 2.

Spacings of fixings.

Usage	Walls		Ceilings	
	10 mm	12.5 mm	10 mm	12.5 mm
Screws (spacing in mm)	250	250	150	200
Nails/Staples (spacing in mm)	200	200	150	200

Spacings of fixings.

Usage	Walls		Ceilings	
	10 mm	12.5 mm	10 mm	12.5 mm
Screws (spacing in mm)	13	10	22	17
Nails/Staples (spacing in mm)	16	12	22	17

Please note: if fixing a second layer to the first layer, use the same spacing.
For more details, phone FERMACELL's technical helpline on 0870 - 6090306.



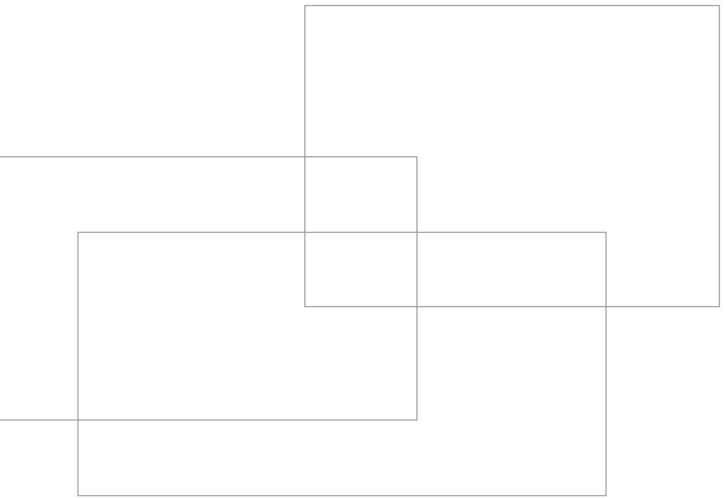

Ceiling Details.

FERMACELL can also be used for ceiling and sloping roof applications. Where FERMACELL is used in these cases it provides an ideal base for subsequent installations of partitions because of its excellent screw holding capabilities. When installing a ceiling using FERMACELL, the same considerations apply as for walls, except that the fixing centres and the spacings of the supporting members are altered in accordance with table 3 opposite.

It is also important to take into account the additional weight of FERMACELL when compared to plasterboard. For this reason it is recommended that help is sought when installing FERMACELL in ceiling applications. The ability of FERMACELL to be fixed to timber substructures using pneumatically applied nails or staples is a particular benefit in these cases.

Table 3 on the opposite page gives full details of the load-bearing members of the supporting structure for ceilings. Where these details are not used, the deflection of the supporting construction must not exceed $1/500$ of the effective span.

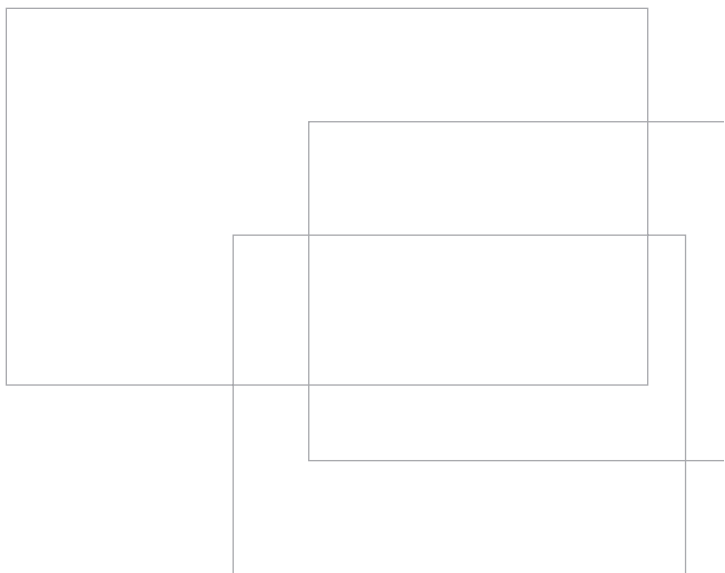

In ceilings where acoustic considerations are important, such as party floor constructions, penetrations should be kept to a minimum. The use of recessed downlighters, for example, will have a serious effect on the acoustic performance of a ceiling construction, and in these circumstances we strongly recommend the use of a sacrificial ceiling.

For details on sacrificial linings, please refer to page 28, adjusting any fixing centres to take into account the different requirements of walls and ceilings. Illustrations of sacrificial ceilings, together with more comprehensive details and instructions are available from: www.fermacell.co.uk

Table 3
Cross-sections of supporting members for suspended ceilings.

Supporting structure in mm		Maximum span in mm	
		single-layer lining	double-layer lining
Sheet steel sections			
Primary bearers	CD 60 x 27 x 0.6	900	750
Supporting sections	CD 60 x 27 x 0.6	1000	1000
Timber battens (width x height)			
Primary bearers, fixed direct to ceiling	48 x 24	750	650
	50 x 30	850	750
	60 x 40	1000	850
Primary bearers, suspended	30 x 50	1000	850
	40 x 60	1200	1000
Secondary bearers (battens)	48 x 24	700	600
	50 x 30	850	750
	60 x 40	1100	1000

The spacings between the supporting sections or battens for horizontal surfaces and linings and undersides of pitched roofs up to 50° angle is 400 mm for 10 mm board or 500 mm for 12.5 mm board. For other thickness of board the spacing is 40 times the board thickness.

Other Details.



Forming door openings – front view



Forming door openings – rear view



Forming door openings – alternative using board extending past door head

Doors and windows.

For door or window openings which are not ceiling height, FERMACELL boards should be cut in a way that the joints between adjacent boards never lie on the vertical C studs or reinforced U channels to which the door or window frame is fixed. Also, the joint between the boards around the opening should always be placed above the head of the door. This joint should be a minimum of 200mm from the edge of the frame. Offcuts should not be used around a door or window frame as they cannot be jointed with FERMACELL Jointstik adhesive.

Horizontal joints between boards should be avoided around door and window frames. If a horizontal joint cannot be avoided (again, off-cuts should not be used), the boards should be jointed using the FERMACELL Jointstik method. (See Jointing section on page 16).

Joints in FERMACELL boards above a door or window head should be on the same stud. Boards installed above openings should be fixed in the same manner as normal partitions. On metal subframes the boards should be fixed to the vertical C studs only, and on timber subframes to both vertical and horizontal members.

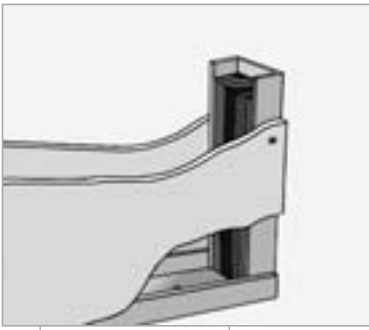

**Timber grounds in
a vertical C stud**

For doors and windows which exert high loads (eg particularly large or heavy doors) it is advisable when using metal sub-frames to pack out the vertical C studs with timber grounds for additional rigidity and to provide a stronger anchorage point for hinges and other furniture. In addition door reinforcements kits may be necessary.

Special Protektor door reinforcement kits are available from Cornercare - telephone +44 (0) 1562 515200. Please refer to the door manufacturer for door weights and loading in these instances.

Other Details.

Adding a second layer of FERMACELL.

Second and subsequent layers of FERMACELL may be added to the first layer by direct fixing to the boards themselves. The joints in the second layer (both vertical and horizontal) should be staggered from the first layer by at least 250 mm. Where two layers are to be fixed, it is not necessary to use FERMACELL Jointstik adhesive to butt joint the first (lower) layer when using square edge boards, however, where tapered edge boards are being used, the joint area of the lower layer must be filled to maintain fire and acoustic integrity.

When fixing FERMACELL to itself in this manner, use either 30 mm FERMACELL screws or galvanised diverging staples whose length corresponds to the combined thickness of the two boards (for staple dimensions and centres, consult FERMACELL).

Where a second layer of FERMACELL is to be fixed directly to the subframe, joints should be staggered by the spacing of one stud and for the second layer 45 mm FERMACELL screws should be used.

The fixing centres for fixing the second are the same as for a single layer application (see the appropriate section).

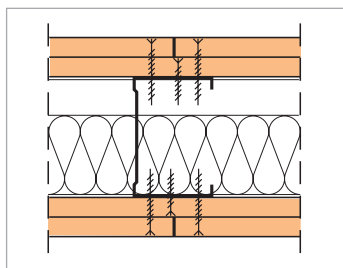

Second layer of FERMACELL fixed to subframe

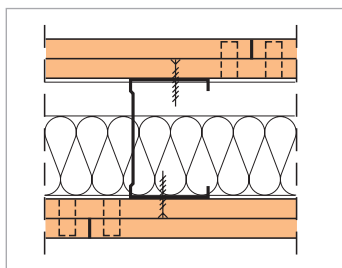

Second layer of FERMACELL fixed to itself

Fittings.





FERMACELL boards have a great hanging strength. And many items can be fixed directly to the boards without fastening to the sub-structure. The table below shows the load bearing capability of a wide range of fittings.

Please note that the load bearing capability refers to static loads only. Where loads are likely to be cyclical, or subject to periodic increase – for example washbasins or stair-rails, the maximum load should be calculated, or reinforcement in the form of pads of FERMACELL or plywood added behind the wall.

Conditions.

1. Safety factor: 2 (permanent loading, with relative humidity of up to 80%).
2. Depth of cupboard or shelves: maximum 350 mm.
3. Standard wallplugs with 4 mm diameter screw. (The wallplug manufacturer's instructions should be followed.)
4. Distance between stud centres: 50 x board thickness.
5. Where spacings between fittings are greater than 500 mm, the load bearing capabilities of the individual fitting can be added. With spacing less than 500 mm, the load bearing of each fixing should be reduced by 50%.

Table 5

Fitting	Load bearing (kg)				
	Thickness of FERMACELL boards in mm				
	10	12,5	15	18	10+12,5
Picture hooks fixed with nails					
	15	17	18	20	20
	25	27	28	30	30
	35	37	38	40	40
Screw with continuous thread 5 mm dia					
	20	30	30	35	35
Cavity plug 8 mm dia					
	40	50	55	55	60

Other Details.

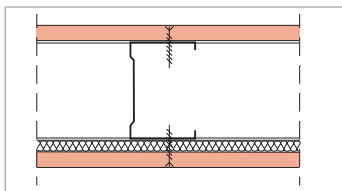

Resilient bars on steel subframe (detail also applies to timber studs)

Internal junction between two FERMACELL partitions

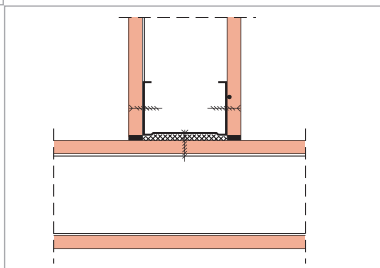

Resilient bars or counter-battening for increased acoustic performance.

Where narrow structures are desirable but it is necessary to increase the acoustic performance still further, the use of resilient bars or counterbattens is recommended. Before mounting the boards, fix resilient bars at right angles to the subframe (vertical studs or floor joists) at the appropriate centres (see table 1 on page 19 or table three on page 29).

Install the mineral fibre batts and then the FERMACELL boards as before. With timber counterbattens the procedure is similar, using 2" x 1" wooden lath. However, before installing the battens, mineral wool strips should be sandwiched between the subframe and the lath.

Junctions.

Because of the excellent screw holding strength of FERMACELL, right angled partitions can be started at any point along a FERMACELL wall by simply fixing the end vertical stud (either metal or timber) directly to the FERMACELL board. As before, boards should be packed out from other building finishes. FERMACELL Joint Filler should be used to finish the joints between boards in these situations, because of the difficulty in removing excess Jointstik adhesive from an internal corner.

When FERMACELL partitions are connected to different building materials such as plaster, fair-faced concrete, masonry, steel, plasterboards or timber building materials, the different materials should always be separated due to differential expansion and contraction rates. By ensuring that there is no rigid connection, subsequent stresses and resulting cracks can be avoided.

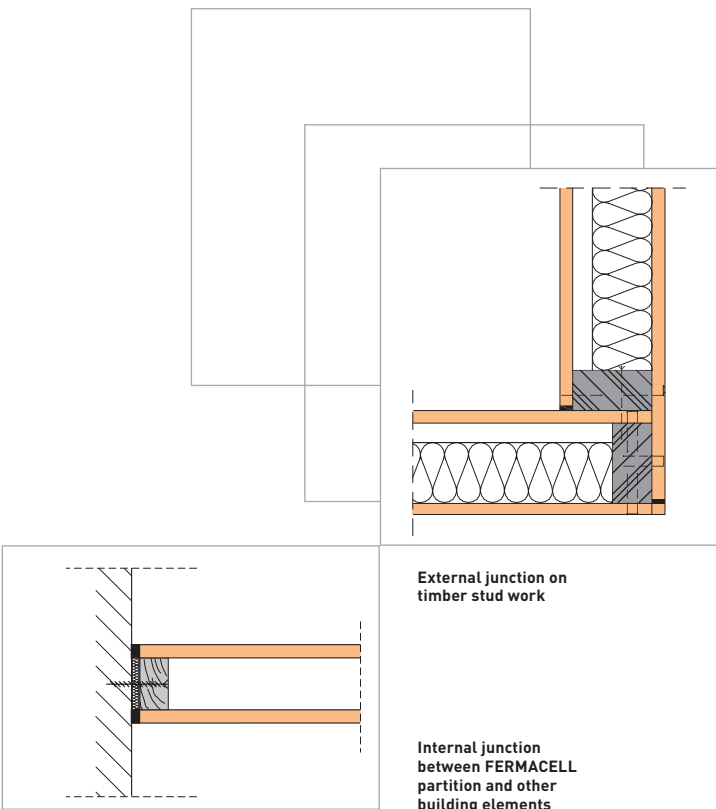

External junction on timber stud work

Internal junction between FERMACELL partition and other building elements

The joints between FERMACELL partitions and adjoining building elements can be closed with a long life flexible sealing material capable of absorbing variations of up to 20 % of the joint width and suitable for use with a gypsum based board. The width of the connecting joint should be 3–5 mm. It is important to note that the edge of the board must also be primed before sealing the joint. Where external corners are required, the boards are fitted in accordance with

the picture opposite. An external angle bead is not required and any damage to the edge of the boards can be touched up with FERMACELL Joint Filler prior to painting or other decoration. Once the boards have been jointed and finished, it may be preferable to profile the external corner into a small radius (2–3 mm) to mimic the effect of plaster bead. If, for aesthetic reasons, a 'sharp' edge is required, a metal reinforced flexible paper tape can be fitted using a PVA adhesive. This is then finished with FERMACELL Fine Surface Treatment (see the relevant section on finishing).

Other Details.

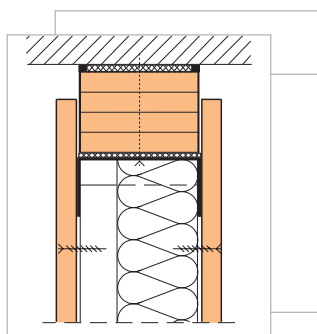

Fire rated Deflection head detail
(timber grounds may also be used – please see section below)

Expansion joint, single layer

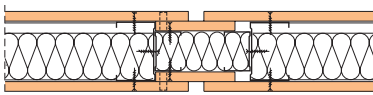

Expansion joint, double layer

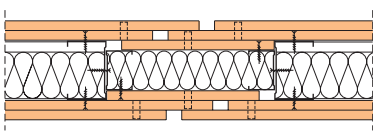

Deflection heads.

Deflection Heads (sliding joints between FERMACELL partitions and structural ceilings) should be incorporated if, after the installation of the partitions, a deflection of the structural ceiling is expected. The Deflection Head must ensure that there are no pressures exerted on the FERMACELL partition from the structure.

Where a fire rated Deflection Head is required, the joint may be constructed using FERMACELL strips which are cut to fit the width of the adjoining U channel. The total thickness of the combined layers of FERMACELL strips should be sufficient to cater for any deflection from the structure plus the required overlapping from the FERMACELL boards.

Alternatively, a timber ground may be used. In general, for a F30 partition the timber ground should be 50mm wide, and for an F60 partition 100mm wide.

Please note that the same principle applies to vertical and horizontal loadings on the building structure.

Expansion joints.

Expansion joints are generally needed in FERMACELL partitions where there are expansion joints in the building structure. Movement joints in FERMACELL partitions should be considered as these can be subject to changes in length (both expansion and contraction), owing to changing climatic conditions in the room. Generally there should be a maximum distance of 8m between expansion joints in FERMACELL partitions.

Wall and ceiling details.

The diagrams below show some of the most commonly used constructions, but form only a small part of those available. Please visit www.fermacell.co.uk for more details.

Walls with steel subframes.

One layer of 12.5mm FERMACELL board on 75mm Protektor steel stud + mineral fibre

Mineral Fibre	Fire Protection	Sound Insulation	Maximum Wall Height
40 mm/45 kgm ⁻³	60 minutes	52 dB	4.5 m

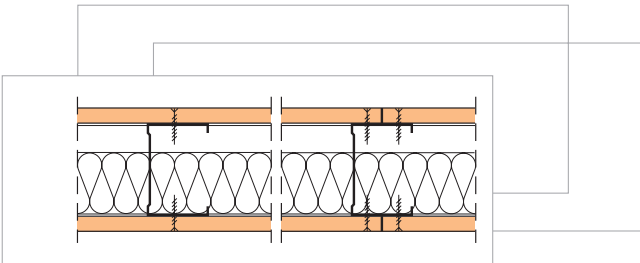

Other Details.

Walls with timber subframes.

One layer of 12.5mm
FERMACELL board on 75mm
timber stud + mineral fibre

Mineral Fibre	Fire Protection	Sound Insulation	Maximum Wall Height
40mm/45kgm ⁻³	60 minutes	44 dB	3.00 m

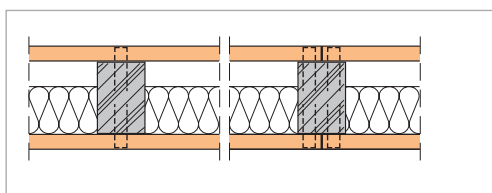

Robust Detail/

Party wall construction

Two layers of 10.0 mm
FERMACELL board on
2 separate 75 mm timber studs
(90 mm gap) + 50mm 45kgm⁻³
mineral fibre

Mineral Fibre	Fire Protection	Minimum Sound Insulation	Maximum Wall Height
40mm/45kgm ⁻³	60 minutes	$D_{ntw} + C_{tr}$ 50dB	3.10 m

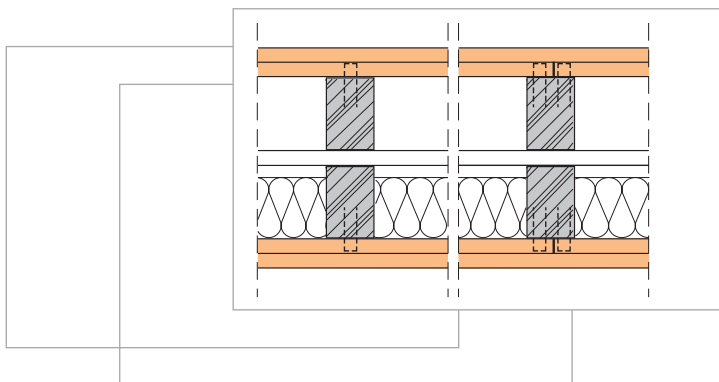

Sound insulating independent wall lining.

12.5mm FERMACELL board on independent 50mm Protektor steel stud + 50mm 45kg/m⁻³ mineral fibre

Mineral Fibre	Fire Protection	Sound Insulation	Additional Wall Thickness
50mm/40kgm ⁻³	30 minutes	+20dB	< 70mm

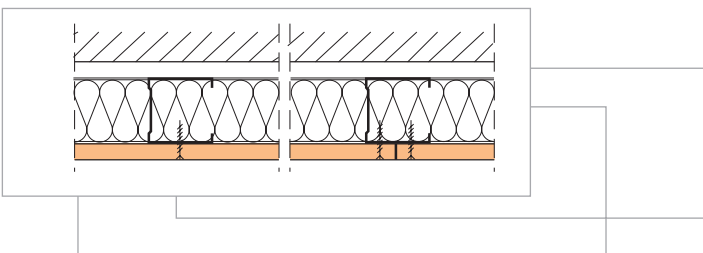

Ceiling constructions

½ hr ceiling (timber joist* and flooring).

One layer of 10mm FERMACELL board to underside of timber joists

Mineral Fibre	Fire Protection	Sound Insulation	Maximum Sub-frame Spacing
-	30 minutes	N/A	400mm

*Based on 225mm x 50mm joists

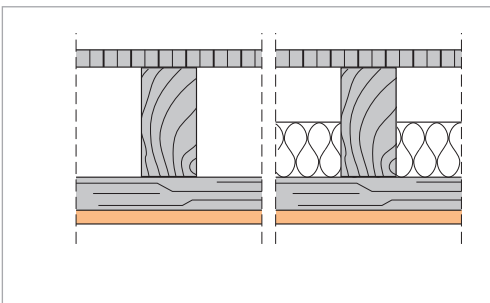

Repairs.

Repairs to boards.

Because FERMACELL has such a high impact resistance, repairs are rarely required. However, if a board is dented then the localised damage can be made good using FERMACELL Joint Filler. If the board has cracked, or the damage penetrates through the board, it is not necessary to remove the whole board as the damaged area can be cut out and a new piece inserted.

Offcuts of FERMACELL are placed around the back of the edge of the cut out section and fixed to the existing board using FERMACELL screws.

A new piece of FERMACELL is cut to size (allow for a 5–7 mm gap around each side), fitted in place and screwed to the offcuts using FERMACELL screws. The gap is then filled with FERMACELL Joint Filler in accordance with the instruction given in the section on jointing (see page 14).

Repairs to corners.

The homogeneous nature of FERMACELL means that corner beads are not required. For this reason any damage at a corner is restricted to the point of impact and does not require the reinstatement of the whole corner. Damage can be made good using FERMACELL Joint Filler.

Cracked joints.

FERMACELL Jointstik adhesive produces a bond stronger than the board itself. Cracked joints are therefore rare and are usually caused by other factors. Before repairing a cracked joint, go through the following checklist to establish the root cause of the failure.

- Is there movement or subsidence in the building?
- Is the partition loaded from above without a deflection head being installed?
- Are there any rigid junctions between the FERMACELL and other building materials?
- (If using Steel subframe) Has the board been fastened to either the head track or the sole plate?
- Is the frame sufficiently rigid?
- Have the doors or wall openings been correctly braced?
- Is the supporting frame at the correct centres for the thickness of board?
- Is the frame profile (either thickness or depth) correct, especially for tall partitions?
- Are the fixing centres correct?
- Are the boards correctly jointed around any openings?
- Have cross/cruciform joints been formed?
- Is an impervious surface coating trapping moisture and resulting in high humidity levels?
- Has the Joint Filler been used correctly – is the joint gap correct for offcuts, has the filler been pushed to the rear of the joint, was the filler mixed in accordance with the instructions?
- Has the Jointstik adhesive been used correctly – is the joint width less than 1 mm?

Once the root cause has been addressed, the following remedial action shown below should be taken:

1. Open the joint and remove any Jointstik or filler. The joint must be opened up to a minimum of 5mm. This may be done using a router or a circular saw set to the correct depth.
2. The joint must then be cleaned removing any dust particles using either a vacuum cleaner or a moist brush.
3. The clean edges should then be primed using a PVA sealant and allowed to dry.
4. Join the clean joints with FERMACELL Joint Filler. Follow the instructions shown on the FERMACELL Joint Filler packet.*
5. Finish off the joint with a fine fill. When this has dried, apply a PVA coat approximately 100mm wide over the joints.
6. Tape over the joint using FERMACELL fibre joint repair tape and allow to dry.
7. Once the PVA has dried, apply a second layer of PVA over the tape and allow to dry. The repair is now complete. For finishing see the relevant section.

*It is also possible to re-glue the two boards using Weiss Cosmofen Duo Beige PU Adhesive. The adhesive comes in a special twin barrel container and requires a twin applicator. Where this adhesive is used, it is not necessary to carry out steps 5-7. Cosmofen is available from the main dealers.

Advanced Technical Products Limited.

Unit C10, Aven Industrial Park
Tickhill Road, Maltby
Rotherham
South Yorkshire, S66 7QR
Tel.: +44 (0) 1709-812333
Fax: +44 (0) 1709-815333
mail:atpsales2000@aol.com

National Seal Systems Limited.

Unit 210 Western Industrial
Estate
Naas Road, Dublin 12, Ireland
Tel.: +353 (0) 1-456 5170
Fax: +353 (0) 1-450 2371
mail:natseal@iol.ie

Cracked joints – tapered edge boards.

FERMACELL tapered edge board joints are not as strong as Jointstik joints – for this reason, tapered edge boards may not be used in load bearing constructions. However, cracked joints are rare and are usually caused by other factors. Before repairing a cracked joint, go through the following checklist to establish the root cause of the failure.

- Is there movement or subsidence in the building?
- Is the partition loaded from above without a deflection head being installed?
- Are there any rigid junctions between the FERMACELL and other building materials?
- (If using Steel subframe) Has the board been fastened to either the head track or the sole plate?
- Is the frame sufficiently rigid?
- Have the doors or wall openings been correctly braced?
- Is the supporting frame at the correct centres for the thickness of board?
- Is the frame profile (either thickness or depth) correct, especially for tall partitions?
- Are the fixing centres correct?
- Are the boards correctly jointed around any openings?
- Have cross/cruciform joints been formed?

- Is an impervious surface coating trapping moisture and resulting in high humidity levels?
- Has paper tape been used, has the filler been pushed to the rear of the joint, was the filler mixed in accordance with the instructions?

Once the root cause has been addressed, the following remedial action shown below should be taken:

1. Open the joint and remove any tape and filler.
2. The joint must then be cleaned removing any dust particles using either a vacuum cleaner or a moist brush.
3. The clean edges should then be primed using a PVA sealant and allowed to dry.
4. Refill the clean joints with FERMACELL Joint Filler and bed in a paper joint tape in accordance with the instructions in the relevant section.

The repair is now complete. For finishing see the relevant section.

Questions and Answers.

DIY

Q Can I really install FERMACELL myself?

A As long as you are reasonably fit, Yes. The board is heavier than standard wall board, so if you are tackling the project on your own, use the One Man Board formats. Otherwise, having read the manual, all of the installation steps are straightforward and logical. If you are using FERMACELL for the first time, start in an area which is out of sight (an airing cupboard for example) where you can practice your technique.

Installation compared to plasterboard.

Q I'm an experienced builder/dry liner – what should I know that's different about FERMACELL?

A It's heavier, and not as easily cut as plasterboard. You should therefore allow more time, or more labour for the project (about 25 % on average). Unless you are using the tapered edge board, the installation sequence does not follow the traditional tacking and jointing technique – each board is edge glued to it's neighbour in sequence which generally lends itself to a three man team rather than two (one for gluing and screwing, and two for placing the boards). The glue dries overnight and is scraped off, the screw (or staple) heads stopped with FERMACELL filler and the board finished according to specification.

Skim		FST	↑ Installed costs, £
Jointing		Jointing	
Insulation		Insulation	
Board Fix		Board Fix	
Board		Board	
Noggins			
Studwork		Studwork	
Supply and Fix		Supply and Fix	
Plasterboard		FERMACELL	

Questions and Answers.

Cost.

Q OK, it's got all the benefits, but what about the cost?

A About three times the price of plasterboard in material terms. But since boards don't stay up on their own, you also need to factor in the cost of the other elements. The studwork is about the same, but you will save money because you don't need noggins. You need to allow for insulation in both cases. Installation is about 25 % more expensive (see the question above). All in all, a like for like partition using FERMACELL will cost about 20 % more than a standard wallboard equivalent. Except that the standard wallboard one isn't equivalent - the FERMACELL variant is impact resistant, carries wall mounted fittings anywhere on the board, has incredible acoustic performance (from 52 dB on steel stud compared to 45 dB for wallboard) and is a moisture rated, one hour fire-wall. To achieve this with plasterboard you must use specialist boards, multiple layers and so on.

Where FERMACELL really wins is when you are considering skimming plasterboard. Assuming you can find a plasterer, the result will take 3 days to dry out and have added anything up to £ 6 per metre to your costs. FERMACELL is already abrasion resistant, but if you want skim coat smoothness, use FERMACELL FST (Fine Surface Treatment) - a ready mixed face filler that binds into the surface of the board and is DIY/non-skilled trade application that dries in 30 minutes and is ready to paint in 45.

In performance terms, the resultant FERMACELL construction is closer to a solid masonry wall than a drywall partition.

Large and non standard size boards.

Q I understand FERMACELL make large boards - tell me more.

A Boards up to 6000 x 2540 mm are available, and we can also make boards as small as 400 mm x 400 mm. They must be ordered through a FERMACELL stockist with a minimum quantity of 200 m². This allows elimination of waste (you can have a board tailored to your floor to ceiling height), or to reduce jointing costs - the cost of plasterboard and tape and jointing is about the same square metre cost of a FERMACELL board, so you get the benefits of FERMACELL for free. This is particularly relevant if you are manufacturing large panels (e.g. SIPs) or modular systems. Also, if you don't have joints in a wall, they can't crack.

Please note that large format boards require special handling and storage - more information is available from the Xella hotline +44 (0)870 6090306.

Cutting FERMACELL.

Q Are any special tools needed?

A No. FERMACELL may be cut with standard woodworking tools. When using a circular saw, use a vacuum attachment, select a blade with fewer teeth – a maximum of 16 is advisable – and reduce the cutting speed. This will prevent excessive quantities of dust being created (the dust doesn't contain anything harmful, but avoidance of exposure to dust generally is good practice). Battery powered skillsaws are ideal.

Fixing.

Q Can I use standard drywall fixings?

A No. FERMACELL is a very dense board and standard fixings will either break or result in failure of the finished construction. All FERMACELL products match the board characteristics – others do not!

Q How else can I fix FERMACELL?

A On timber structures, FERMACELL may be fixed using special staples. Recommendations on staple dimensions are contained in the handy guide, and staple guns and accessories are available for hire or purchase through trade outlets. Contact the manufacturers for details of local outlets. BeA (01482 861075), Haubold (0151 479 3010), SENCO (01925 445566) and Young Black (01793 838400) manufacture a range of tools suitable for this type of work.

It is also possible under special circumstances to nail FERMACELL to steel studwork. Please contact the xella hotline for further details.

Jointing.

Q Is FERMACELL available in a taper edged format?

A Yes. This has been recently introduced to allow the high performance benefits of FERMACELL to be used in conjunction with conventional dry lining techniques. The product is available in 2400 x 1200 x 12.5 mm format with a tapered edge on the two long sides, and in the handy 1200 x 1200 x 12.5 mm 'One Man Board' with a tapered edge on all four sides. The product is available to order through FERMACELL distributors.

Q How do I finish the joint?

A Once the Jointstik adhesive has dried, it can be removed with a scraper and the glue line and screw heads filled with filler. The joint area is then finished with a filler slurry applied with damp decorator's sponge in a circular, dabbing motion. This will match the joint to the slight texture present on the rest of the board. A mist and two top coats of undiluted paint can then be applied. For very smooth finishes use FERMACELL FST.

Questions and Answers.

Q How do I detail external angles?

A Allow the first board to extend past the corner of the stud by its own thickness (due to shrinkage, best results are obtained using metal stud). Fix the second board leaving a 5–7mm gap between and fill using Fermacell Joint Filler. If using Jointstik, fix the first board flush with the corner of the stud, apply a bead of Jointstik along the edge of the fixed board and fix the second board. Angle beads are not necessary. Once the boards have been jointed and finished, it may be preferable to profile the external corner into a small radius (2–3mm) to mimic the effect of a plaster bead. On partitions where a sharp edge is required (typically in commercial applications), a paper reinforcing tape can be used in conjunction with FST.

Q When do I use Jointstik and when do I use FERMACELL Joint Filler?

A In general, use Jointstik whenever possible. If the edges of the boards are uneven – for example when using offcuts, then FERMACELL Joint Filler should be used. Because Jointstik takes 24 hours to harden, the filler method can be used if a job needs to be completed quickly. Remember – do not mix the two techniques – Jointstik is not a gap filling adhesive and glues the boards together as they are installed; FERMACELL Joint Filler is applied once all boards have been fitted to the 5–7 mm gap left between the boards.

Fire.

Q Is FERMACELL a F30 (1/2 hr) board?

A Fire ratings come from the overall construction, not the individual board. A variety of constructions are shown on our website, together with data-sheets.

Finishing.

Q What's special about FERMACELL filler?

A It's a combined filler, sealant and adhesive. Joints made with FERMACELL will won't crack. It also sets very hard, so don't be tempted to put too much on or you will spend all your time sanding it back. When mixing it, use clean tools, bucket and water – every time – and put the water in first, adding the filler after. Once the filler has soaked up the water, WAIT – allow it to slake for 5 minutes before gently mixing it into a consistent goo. This way, it will last up to 35 minutes before going off. If you mix it mechanically, it will set prematurely.

Q Can I skim FERMACELL?

A Yes, although it is not necessary as FERMACELL will accept direct decoration. The board is presized, but we recommend that a PVA sealant is applied first as some finishing plasters can craze in certain conditions. When skimming, jointing must still be carried out using Jointstik and joints should be taped. A finish identical to skim plaster can be achieved by using FERMACELL FST which is dry in 45 minutes, is non-skilled and costs a fraction of the costs of specialist plasterwork.

Q What about paint, tiles or wallpaper?

A Paint should be applied as a mist coat and two undiluted top coats. Tiles can be fixed directly. In areas such as showers, a waterproof mastic is recommended. All wallpapers except vinyls can be applied without priming. On vinyls, use a low water content paste.

Moisture.

Q Is FERMACELL waterproof?

A It can be used in domestic showers or bathrooms, or in semi-exposed applications such as soffit, and areas of high humidity (up to 80 % Rh). It's OK for carport ceilings, but not for facades.

Q Can I use FERMACELL in swimming pool applications?

A Not recommended. This is because, whilst the pool area may be ventilated mechanically, air conditioning can break down causing the relative humidity to exceed 80 % Rh. In these conditions, the board can soften and sag.

Q Is FERMACELL available as a foil backed board?

A No. Where a vapour barrier is required (and generally it is good practice to have a condensation risk analysis -CRA - completed before one is omitted from the construction) we recommend the use of a 200 g (min) VCL sheet fixed to the face of the studs, with joints overlapped by 200 mm and taped. This will ensure that a continuous and effective vapour barrier is provided. Foil backed boards cannot, by definition, be sealed at joints.

Dot and dab.

Q Can I fix FERMACELL to masonry walls using plaster dabs?

A Yes, although this method is not recommended because the unique strength of FERMACELL can be compromised by the weakness of this method. A better solution is to use a direct mechanical fix – metal firrings or timber battens – and then fix FERMACELL to this substructure. This method also allows a greater choice of readily available insulation. If you are using this method, then select Tapered Edge boards.

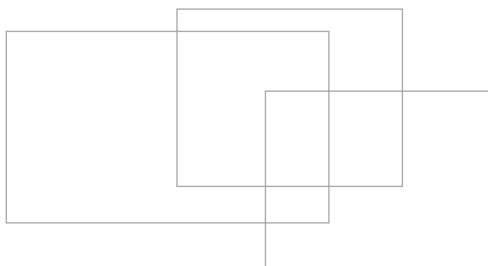

Questions and Answers.

CLS Timber.

Q Can I fix FERMACELL to CLS (38 mm x 89 mm) section timber?

A Yes, but added care should be taken because of the narrower fixing face (we generally recommend a 50 mm wide fixing face). When using CLS, fix the boards with pneumatically applied nails or staples, and the CLS should be graded as straight as possible. It is not practical to use the filler method of jointing with this narrower timber and fire certification is limited to a maximum of F 60. Please check with the Xella hotline for further information.

Timber vs. Steel studwork?

Q Why should I use one sort or another?

A This is largely down to personal preference on site, although each has it's benefits. Timber is more familiar, and often more readily available. It also allows the FERMACELL board to be stapled to the studwork, which is a very fast and cost effective method of installation. Steel studwork is more stable, and can be more precise. Cutting steel sections with tin snips is quicker and installation of the studwork faster (the vertical 'C' studs are held in position by the 'U' channel at top and bottom without any mechanical fix). Acoustic performance with steel studwork is far better because of the reduced transmission path across the partition.

Please note that the fixing techniques are different, and that changing profile thickness from that stated in the construction tables may have an adverse effect of performance. This advice applies to non load bearing structures only. Pay specific attention to the notes regarding installation sequence and do not fix the board to the U Channels.

Steel studwork.

Q Does Xella make steel studwork for use with FERMACELL or can I use any type?

A Xella does not make steel studwork although we strongly recommend the use of Protektor studwork and metal accessories. Other stud types have not been tested by Xella and as such are not warranted as a system; the majority of other makes that are available are made from thinner gauge steel and the additional mass of the FERMACELL board means that a thinner section may not provide sufficient rigidity. Protektor studs have a 0.6 mm gauge and a 50 mm fixing face.

The studs and accessories are available from Cornercare (telephone 01562 515200).

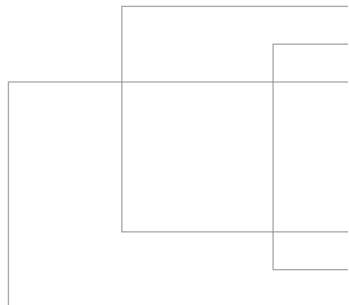

Mineral Fibre Insulation.

Q Why are there variations in the thickness and density of the Mineral Wool?

A Virtually all FERMACELL constructions are multipurpose – construction 1 S 21 for example is a moisture resistant, 52 db sound insulating, impact resistant, weight carrying wall that can be One hour fire rated up to 10 m. The insulation used, together with the studwork configuration, contributes to these remarkable attributes. Varying thickness or density of mineral wool can affect the thermal, fire and acoustic insulation properties of a particular construction. In general, greater thickness of mineral wool will positively influence all insulation properties, although with densities above 20 kg/m³ acoustic insulation improvements may be limited. When using mineral wool insulation to improve acoustic insulation, avoid over-filling the cavity as this can lead to acoustic bridging and a reduction in the acoustic performance of the construction. A maximum of 80 % (depth) fill is recommended.

Sound.

Q If I fix FERMACELL direct to the wall, will I silence noisy neighbours?

A A little, but best results are obtained by constructing an independent lining that is less than 75 mm deep.

Q What about the acoustic regulations (Part E, BB93 and HTM56)?

A The new regulations have not only increased the acoustic performance requirements between rooms, but have added a significant requirement for on site testing of the finished constructions. FERMACELL sponsor a web site dedicated to these new regulations which contains links to other regulatory sites, testing authorities, a simplified explanation of the new requirements of Part E and the parallel regulations for schools and hospitals (BB93 and HTM56 respectively), the Robust Detail process and a full listing of the constructions tested to comply with these requirements. For more information visit www.part-e.info.

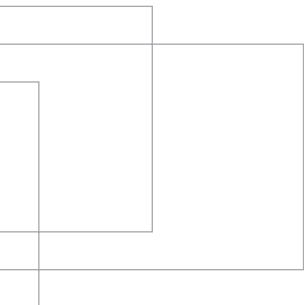

Product Range

Wall boards

- Use 10mm thick board for most domestic applications
- 12.5mm thick board is available for heavy duty domestic and commercial applications
- 15mm and 18mm boards are manufactured for specialist applications such as modular buildings
- All boards are available in full board size (2400 x 1200mm) or as one-man boards (1500 x 1000mm)

Accessories

- FERMACELL screws (3.9 x 30mm) must be used with a high speed screwdriver. See page 27 for fixing centres
- FERMACELL Jointstik must be used to give "no-crack" joints
- FERMACELL Joint Filler must be used to fill and seal gaps between offcuts or for filling screw heads
- FERMACELL Fine Surface Treatment may be applied simply by squeegee to give a "glass" finish without the need to skim





Technical changes may be made. Correct at 10.2004
The latest version of this brochure, together with our complete
catalogue of brochures and datasheets is available online at

www.fermacell.co.uk

If you do not have Internet access, please call our
Technical Hotline on +44 (0) 870 6090306

Xella Dry Lining Systems
P.O. Box 10028
Sutton Coldfield B75 7ZF

Telephone: + 44 (0) 870 6090306
Telefax: + 44 (0) 870 2402948
www.fermacell.co.uk