

Ytong Multipor Mineral Insulation Boards

# Underground garage and basement ceiling insulation





Large parking garage below Westphalia Hall B3 in Dortmund

## Ytong Multipor: The insulation system for basement and underground parking facilities

Ytong Multipor Mineral Insulation Boards are ideal for a light and friendly atmosphere - a dark "bunker appearance" is out.

Underground garage ceilings and driveways are frequently insulated poorly if at all. Valuable heating energy escapes through walls and ceilings. This results in a cold, unpleasant room climate in the residential and office rooms above. Buildings for the future require maximum thermal insulation and energy efficient construction methods. This applies for renovation as well as new construction of underground garages and basements. In addition to thermal insulation, fire protection plays an increasingly important role for basements and underground garages; and this fire protection does not apply only to escape and rescue routes. Non-combustible insulating materials which do not develop smoke or toxic gases in a fire are being used more and more frequently due to experience in the past.

The monolithic and mineral Ytong Multipor insulating system is particularly well suited for large area insulation work as well as for basement or underground garage ceilings with many angles and subdivisions.



# "Tradesmen don't like using unfamiliar materials ..."

## Prejudices and advantages

Common underground garage insulation materials such as excelsior insulating boards and mineral wool have been available for many years. Isn't it about time to try something new?

### **... new, unfamiliar and no experience**

#### **Not entirely true!**

The Ytong Multipor insulating system has proven itself well over a decade on ceiling and walls. Our experienced demonstration consultants are available for support for your next project with Ytong Multipor.

### **... complicated to use**

#### **Not at all!**

These solid non-deforming insulation boards can be glued on quickly and reliably right down to the smallest angle – without any drilling, anchors or screws whatsoever.

**More on Pages 8–9**

### **... certainly too expensive**

#### **On the contrary!**

In addition to the material costs, minimum processing times also provide clear cost advantages for complicated details.

### **... not approved**

#### **Simply request!**

The Ytong Multipor Mineral Insulation Boards are a silicate insulating material and have a European Technical Approval ETA-05/ 0093 as well as a General Construction Supervisory Approval Z-23.11-1501.

**More on Page 5**

### **... what about fire protection?**

#### **Very simple!**

The Ytong Multipor Insulating System consisting of mineral insulation boards in fire classification A1, and the light mortar, is non-combustible. In the event of a fire, the system components do not form any toxic gases and are therefore exceptionally

suitable for all garages and as fire protection renovation method for "old" concrete ceilings ABP P-3383/4785-MPA BS.

**More on Page 6**

### **... and disposal**

#### **No problem!**

Ytong Multipor is not classified as special or hazardous waste. Ytong Multipor insulation boards do not contain any pollutants. This eliminates the usual disposal problems for insulating materials.

**More on Page 5**

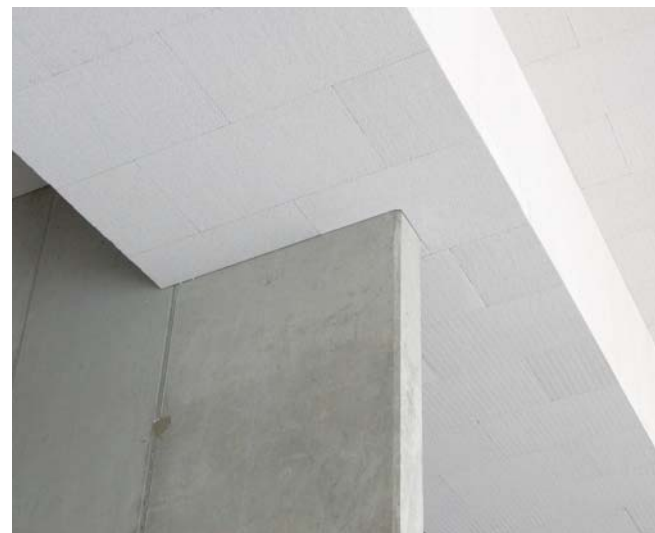

# Ytong Multipor Mineral Insulating System

Their extraordinary mineral properties and simple processing make Ytong Multipor Mineral Insulation Boards the optimum insulating material for basements and underground garages.

## Ytong Multipor Mineral Insulating Plates

Minerally and ecologically Ytong Multipor Mineral Insulation Boards offer a new quality for thermal insulation:

- homogeneous
- high thermal insulation factor
- non-combustible
- stable shape, non-compressible
- open for vapour diffusion
- water repellent
- ecological

## Production

Ytong Multipor Mineral Insulation Boards are produced in an ecological and energy-saving process using the raw minerals lime, sand, cement and water under steam pressure.

## Ytong Multipor light mortar

for gluing, reinforcement and plastering

- natural white
- easy processing
- high adhesive force

- good stability
- high yield (30 l/20 kg)
- water repellent
- open for vapour diffusion
- frost-resistant
- non-combustible

Delivery and processing instructions:

- Storage: Store dry on pallet, up to 12 months
- Delivery form: 20 kg/Sack
- Processing time: approx. 1.5 h
- Ambient temperature:  $\geq 5\text{ }^{\circ}\text{C}$
- Consumption<sup>2)</sup>: approx. 3–4 kg/m<sup>2</sup>

## Ytong Multipor repair mortar

For repairs and filling damaged points

## Accessories

Ytong Multipor measuring bucket

- to ensure optimum processing consistency of light mortar

## Processing tools

- Ytong Multipor reveal board
- Ytong Multipor insulating wedge



- Toothed trowel  
(< 140 mm board thickness = 10 mm, for board thickness greater than 160 mm = 12 mm)
- Electric drill with mixer
- Hand saw
- Ytong Multipor sanding board

## Installation aids

- Wall connection channel, L channel
- Battens
- Slip protection for wall insulation

Technical Data		
	Ytong Multipor Mineral Insulation Boards	Ytong Multipor lightweight mortar
Approval	European Technical Approval ETA-05/0093 General Construction Supervisory Approval Z-23.11-1501	
Areas of application	Top and bottom ceiling insulating system: Underground garages, basements, driveways (DI, DEO, DZ)	
Density	approx. 115 kg/m <sup>3</sup>	
Thermal conductivity	$\lambda = 0.045\text{ W/mK}$	$\lambda_{10, \text{dry}} = 0.18\text{ W/mK}$
Water vapour diffusion resistance coefficient	$\mu = 3$ open for vapour diffusion	$\mu = \leq 10$
Fire classification	Non-combustible - fire classification A1 according to DIN EN 13501-1	A2 - non-combustible
Compressive strength	Average $\geq 300\text{ kPa}$	CS II - 1.5 - 5.0 N/mm <sup>2</sup>
Bending strength	$\geq 80\text{ kPa}$	
Water absorption coefficient	for short-term immersion to DIN EN 1609 $w_p = 2.0\text{ kg/m}^2\text{ W2}$ for long-term immersion to DIN EN 12087 $w_{lp} = 3.0\text{ kg/m}^2$	

Board formats <sup>1)</sup> /quantities	
Length x Width 600 x 390 mm	
Thicknesses	m <sup>2</sup> /pallet
50 mm	33,70
60 mm	28,08
80 mm	21,06
100 mm	16,85
120 mm	14,04
140 mm	11,23
160 mm	9,83
180 mm	8,42
200 mm	8,42

<sup>1)</sup> Special dimensions available on request/<sup>2)</sup> depending on sub-surface and teeth

# The top class for underground garages

## Advantages

### Quick adhesion

Ytong Multipor Mineral Insulation Boards can be installed quickly and easily by simply gluing them to the walls and ceilings with Ytong Multipor light mortar. The quick adhesion installation is particularly advantageous on highly structured ceilings or on joists. Experienced workmen achieve high installation rates on large surfaces.

In contrast to many conventional insulating solutions, our system eliminates annoying and time-consuming drilling, anchoring and screwing. Minimum processing times provide clear time advantages.

### Lower wage costs

### Easy to process

The handy format and low weight of Ytong Multipor Mineral Insulation Boards makes them easy to install overhead on underground garage ceilings. Fitted pieces and cut-outs around pipe passages can be cut easily and precisely.

### Easy handling

### Clean surface

Minor irregularities in the subsurface can be compensated easily using Ytong Multipor light mortar. Projections at joints can be easily sanded down flat with a sanding board.

### Spick and span

Ytong Multipor Mineral Insulation Boards can be left as a visible surface or finished with a standard commercial silicate facade paint which allows vapour diffusion. To obtain a joint-free surface, apply an approx. 2 mm thick coat of Ytong Multipor light mortar as filler plaster.

### Aesthetic

Ytong Multipor Mineral Insulation Boards give underground garages a light, friendly atmosphere.

### Simple repair

Minor damaged spots in the homogeneous Ytong Multipor Mineral Insulation Boards can be repaired very easily with Ytong Multipor repair mortar. Time-intensive replacement of entire insulating boards is eliminated.

### Low subsequent costs

### Water repellent

Ytong Multipor Mineral Insulation Boards are treated to ensure that they are water repellent inside and out. Rain storms during the construction phase are no problem at all.

The following test was performed for an underground garage in a flooding area: An Ytong Multipor mineral insulation board was bonded to a concrete ceiling element and immersed in water for three days.

The impressive result was that the

boards were undamaged, the bond held and the full insulation function was restored after a few days of air drying. In such circumstances, other insulating systems require expensive replacement and disposal.

### Safe during carcass construction

### Ecologically perfect

Ytong Multipor Mineral Insulation Boards have been awarded the certificate EPD-XEL-2009212-D ([www.ytong-multipor.de](http://www.ytong-multipor.de)) by the Institut für Bauen und Umwelt [German Construction and Environmental Institute] (IBU), previously known as "Arbeitsgemeinschaft Umweltverträgliches Bauprodukt e.V." classifying them as biologically unobjectionable and recommendable for biological construction. Moreover, wastes and residues can be disposed of easily as construction rubble.

### Simple to dispose of

### Sustainable product for long-term use



Natureplus quality symbol

Stable shape, non-combustible, water repellent, quick and economical

# Thermal and acoustic insulation, fire protection

## Building physics

### Thermal insulation

Ytong Multipor Mineral Insulation Boards consist of 100% homogeneous material with a thermal conductivity of  $\lambda = 0.45 \text{ W/mK}$  over the entire board thickness. Excellent values can be achieved in this manner.

Thermal resistance R (m <sup>2</sup> K)/W	
Thickness	(m <sup>2</sup> K)/W
50 mm	1,11
60 mm	1,33
80 mm	1,78
100 mm	2,22
120 mm	2,67
140 mm	3,11
160 mm	3,56
180 mm	4,00
200 mm	4,44

The gluing system prevents thermal bridges such as frequently occur with rail or anchor systems.

### Minimum energy loss

### Protection against moisture

Solid Ytong Multipor Mineral Insulation Boards not only provide excellent thermal insulation, they are also open for vapour diffusion. This ensures that the Ytong Multipor light mortar hardens quickly allowing the concrete ceiling to continue curing.

### System open for vapour diffusion

### Fire protection

The non-combustible Ytong Multipor mineral insulating boards and associated light mortar ensure absolute safety for basement ceilings, driveways and below ceilings in underground garages. Ytong Multipor does not develop any toxic vapours or smoke even at the highest temperatures - a true advantage when trying to find the escape route while performing vital rescue measures during a fire.

### Absolutely non combustible

### Acoustic insulation

Running engines, squeeling tires and driving noises from cars entering and exiting frequently lead to annoying noise levels in underground garages.

In comparison to concrete, which reflects nearly all sound, Ytong Multipor absorbs a portion of the acoustic energy (acoustic absorber class D) according to DIN EN 11654 and its porous material structure provides for effective reduction of noise in parking building facilities.

### Noise absorbing

### Fire resistant classes

In underground garages high requirements are placed on ceilings and walls in terms of fire protection. If supporting solid ceilings, do not provide the thickness required for covering the reinforcement in compliance with DIN 4102-4 for fire protection, they can be upgraded to the appropriate fire resistance class by covering on the bottom with Multipor mineral insulation boards (glued with Ytong Multipor light mortar) even in minimum thicknesses.

### Completely safe fire protection

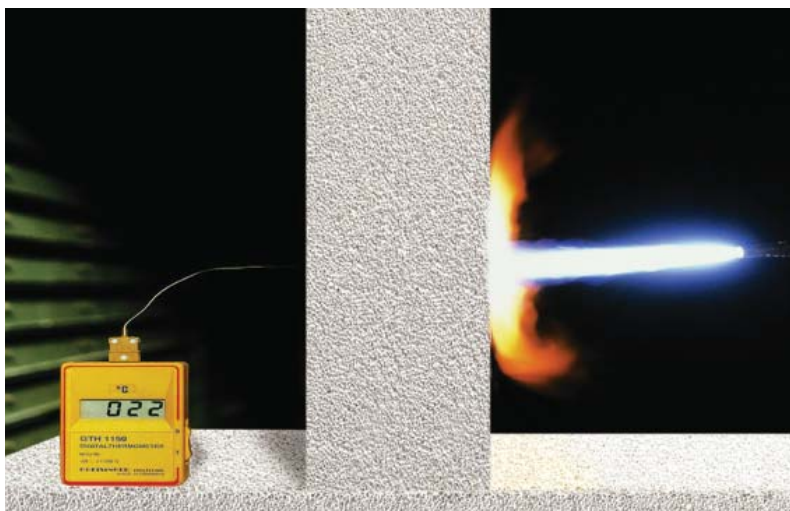



# Details are important and so simple

## Ytong Multipor Installation Instructions

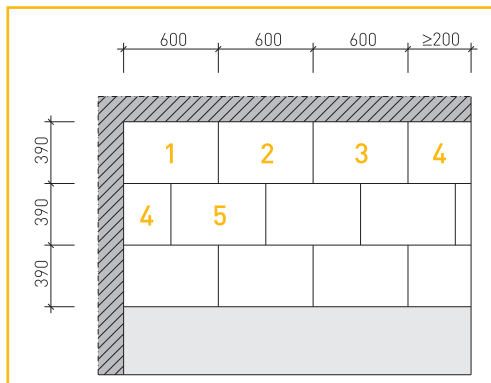

Before starting installation check to ensure that the surfaces are at right angles to one another and mark with a marking line. Lay with boards offset, glue crosswise to the running direction, joints offset.

## Ytong Multipor installation sequence

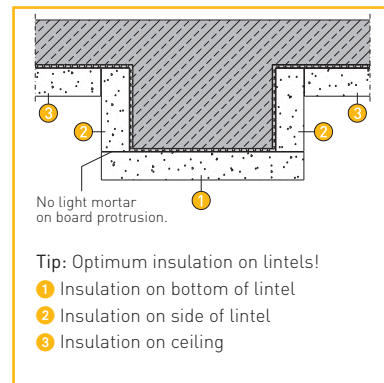

## Fastening connection – Version 1

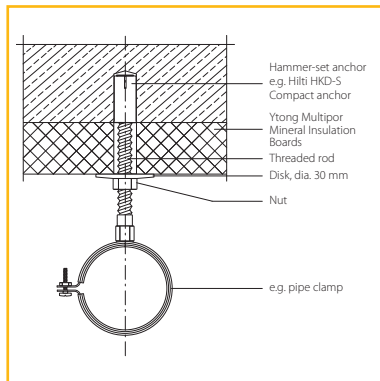

## Corner connection – Version 2

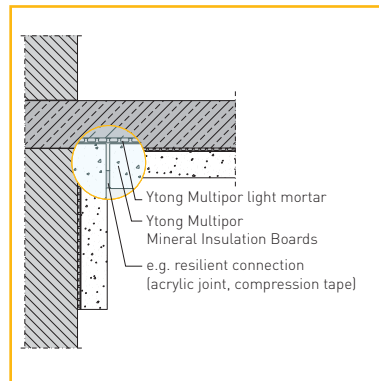

## Corner connection – Version 3

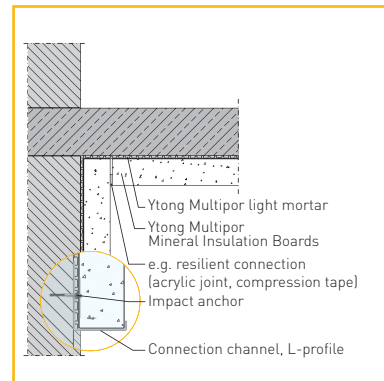

## Corner layout – Version 1

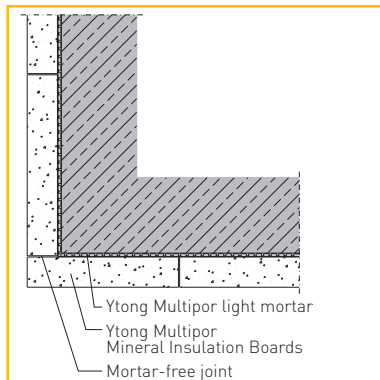

## Corner layout – Version 2

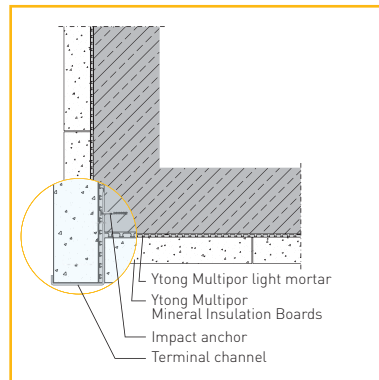

# In no time at all: ready to use!

## Processing

**PROFESSIONAL TIP:**  
We recommend wearing eye protection when working overhead and performing sanding work.

### Mix light mortar ...



20 kg of light mortar mixed with 8 l of water (mark on measuring bucket) yields approx. 30 l of adhesive mortar.

### and apply



Apply over full surface and comb through with toothed trowel (10 mm or 12 mm teeth). Thermal bridges at least 70%.

### no drilling or anchoring



Base height of light mortar approx. 8–10 mm. This allows irregularities up to 3 mm in the subsurface to be compensated.

### Position board on ceiling ...



Position mineral insulation board with light mortar applied immediately on ceiling at interval of approx. 2 cm from adjacent board.

### press down ...



Press against ceiling surface with appropriate pressure.

### slide into position. Finished!



Press with palm of hand and slide against previously glued board. Remove any mortar pressed out and thereby ensure that butt joints are free of mortar.

### Sand down if necessary



Offset points in the insulating surface can be levelled quickly and easily with a sanding board after setting.

### And one more thing!

It is not necessary to support the boards while the mortar hardens.

On walls insulated over the entire area with Ytong Multipor Mineral Insulation Boards, we recommend applying reinforcement plaster consisting of Ytong Multipor reinforcement mesh + Ytong Multipor light mortar to protect against mechanical loads.

# Ytong Multipor underground garage insulation: nothing is simpler

## Fitted pieces



Simple to cut exactly with hand saw.

## Levelling cut edges



Perfectly flush with a sanding board.

## Rational mortar application



Layout a number of boards next to one another and apply light mortar.

## Wall insulation



Fasten terminal channel to wall with impact anchors.

## With terminal channel



Position insulation board with light mortar applied in channel and press down.

## Without terminal channel



Roof lath as installation aid (5 to 10 minutes).

## Insulating joists



Bottom first. **Important:** No Light mortar on board protrusion.

## Surface treatment

The Ytong Multipor Mineral Insulation Boards can be finished with a common commercial silicate facade paint. The surface can also be filled with Ytong Multipor light mortar with a layer thickness of approx. 3 mm and promptly floated with a felt float. If a final coat of plaster is planned, it is necessary to anchor the boards previously (one anchor per board) and apply an approx. 5 mm thick reinforcement layer consisting of Ytong Multipor light mortar and Ytong Multipor reinforcement mesh.

## Connections

Connection insulation on adjacent walls:

- Use form-fitted connection if possible
- Resilient joint seal (e.g. acrylic filler)
- Swelling tape

# A picture is worth a thousand words

The Ytong Multipor insulating system has proven itself on more than 1 million square metres on ceiling and wall surfaces. And naturally we also have references.



Forum Duisburg



Ceiling insulation above entrance to large garage



University of Leipzig



Lintel covering with wall connection



Easy adaptation to all types of supports

**Ytong Multipor – aesthetic, light and friendly**



Note: This brochure was published by Xella Deutschland GmbH. Our publications provide advise and information according to the best of our knowledge and the state of the art at the time of publication.

Since legal rules and regulations are subject to change, this information is not legally binding.  
It is necessary to check the applicable regulations in each individual case.

#### **Xella Customer Information**

Telephone: 08 00-5 23 56 65 (freecall)

Telefax: 08 00-5 35 65 78 (freecall)

**[www.ytong-multipor.de](http://www.ytong-multipor.de)**